



PROTK

proTK™

Neutron Flux Monitoring System

The neutron flux monitoring system proTK™ combines long term experience in design and manufacturing of both detectors and signal processing electronics.

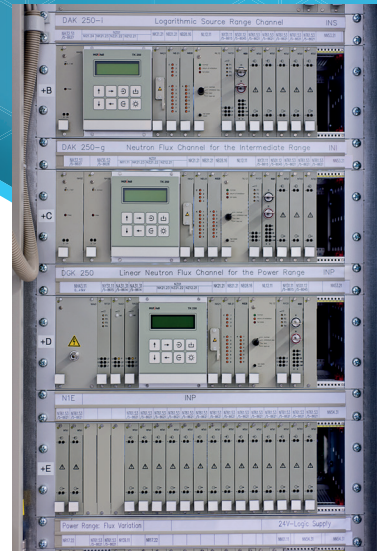

FEATURES

- Modular construction
- Versatile applications
- Robust and reliable in operation
- Type tested
- Proven by operational experience

DESCRIPTION

The neutron flux monitoring system proTK combines long term experience in design and manufacturing of both detectors and signal processing electronics. These products are strictly oriented to the highest level of safety relevance and reliability and are qualified by several type tests and proven by an excellent operational experience.

The system proTK covers the requirements for measuring equipment used for the reactor protection system according to IEC61226 Cat A.

NEUTRON FLUX RANGES

The tables show the combinations of detectors and signal processing electronics for the different types of reactors and the usual ranges:

Type of Reactor	Neutron Flux Range		Code	Detector		Signal Processing Electronics	Quantities
				Position	Type		
Pressurized water reactor (PWR) & research reactors	Start-up range	Pulse range *	SRM	Ex-core	B10- or BF3-proportional counter	Start-up Channel DAK 250-i	2 ... 3 channels *
		Intermediate range *	IRM		Compensated ionization chamber KNK 50 SAC	Start-up Channel DAK 250-g	2 ... 4 channels *
		Wide range	WRM		Ex-core wide-range fission chamber	Wide Range Channel DWK 250	3 ... 4 channels
	Power range	Power range	PRM	In-core	Non-compensated ionization chamber KNU 50	Power Range Channel DGK 250	8 ... 16 detectors, 4 DGK
		Flux distribution monitoring			SPN-detector	Power Distribution Channel DLK 250	24 ... 48 det. 3...6 DLK
Boiling water reactor (BWR)	Start-up range	Pulse range *	SRM	In-core	Pulse mode fission chamber	Start-up Channel DAK 250-i	3 ... 4 channels *
		Intermediate range *	IRM		AC mode fission chamber	Wide Range Channel DWK 250	3 ... 4 channels *
		Wide range	WRM		Wide range fission chamber	Wide Range Channel DWK 250	3 ... 4 channels
	Power range	Local power range	LPRM	-	DC mode fission chamber	Local Power Range Channel DSK 250	80-192 detectors, 20-48 DSK
		Average power range	APRM		(Signals of all DSK 250)	Average Power Range Channel DMK 250	3 ... 4 channels

* may be replaced by wide range

Sensing Systems Division products

Radiation Monitoring Systems Division products

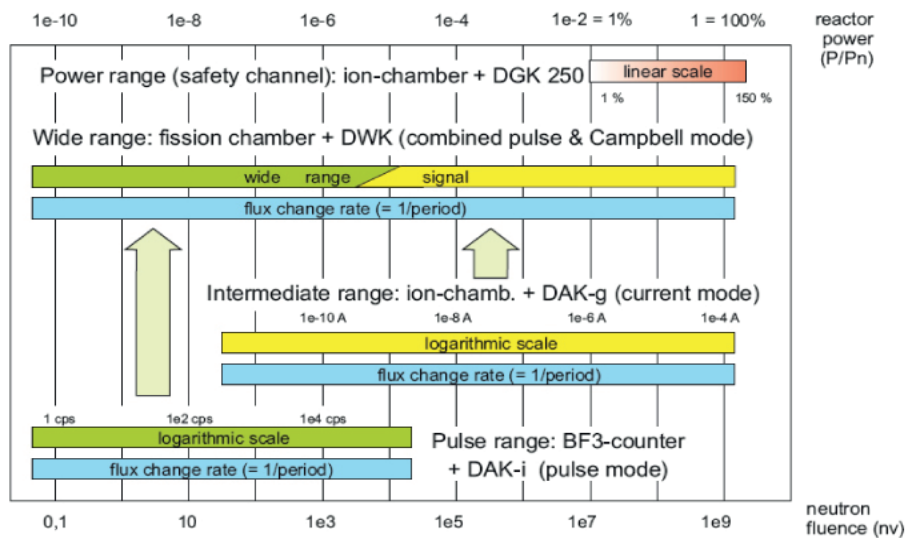

NEUTRON DETECTORS

BF3 Neutron Counters (1") e.g. WL 23057

- Proportional counter tubes for the pulse range
- High sensitivity due to filling with enriched BF3 gas
- 1" (25.4 mm) diameter
- Proven construction
- Large measuring range
- Very low gamma sensitivity
- Manufactured by Mirion Technologies (IST) Corporation

Neutron Ionization Chambers KNK/KNU 50

- For intermediate range and power range
- Ionization chambers coated with enriched B10
- Simple and rugged construction
- Saturation proof
- Large and steady sensitive length
- Output signal: DC current starting at 1 pA
- Compensation of gamma radiation (KNK 50)
- LOCA proof (KNK 50 SAC)

SPN-Detectors e.g. WL 23215

- For in-core power distribution monitoring
- No detector supply voltage required
- 1.6 mm diameter
- Proven construction
- Large measuring range up to $1e15$ nv
- Output signal: DC current
- Very low gamma sensitivity
- Manufactured by Mirion Technologies (IST) Corporation

DIGITAL SIGNAL PROCESSING CHANNELS

Digital neutron flux monitoring channels system proTK are characterized by efficient functions, useful procedures for periodical testing, a comfortable operators menu structure and a rugged operational behaviour. Hardware and software are arranged in modules. The internal multiprocessor structure offers the flexibility of reducing the region of highest safety relevance to a small, separated part within the channel.

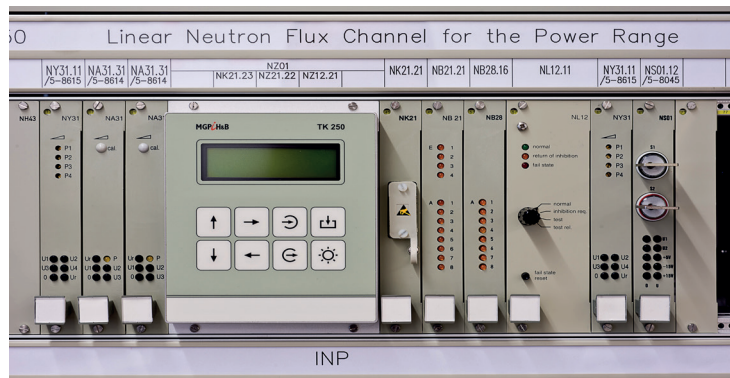
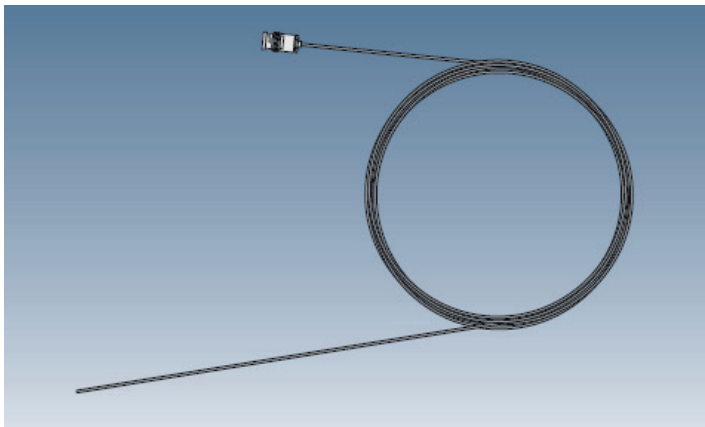
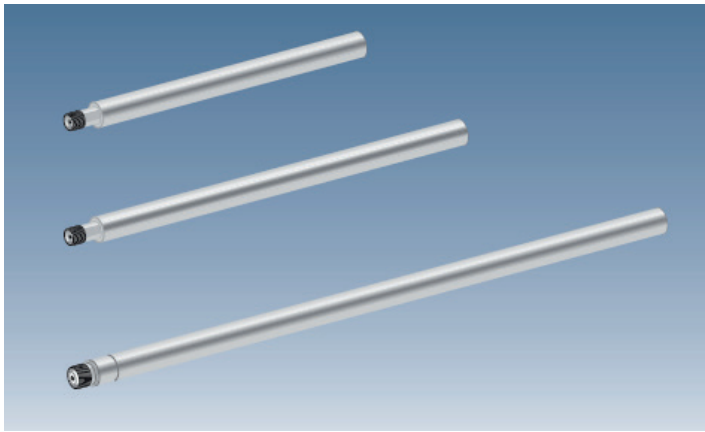

The signal processing system TK 250 includes neutron flux monitoring channels for BWR and PWR, and for research reactors, which are designed and qualified for applications within the reactor protection system:

DAK 250 DIGITAL START-UP CHANNEL

- For the pulse range (DAK 250-i) with pulse detectors and for the intermediate range (DAK 250-g) with ionization chambers with linear or logarithmic output signal and reactor period signal, optional module for reactivity calculation

DWK 250 DIGITAL WIDE RANGE CHANNEL

- For combination of pulse and Campbell (RMS) signal processing together with in-core (BWR) or ex-core (PWR) fission chambers with pulse, intermediate, and wide range flux signal and reactor period signal

DGK 250 DIGITAL POWER RANGE CHANNEL DLK 250 POWER DISTRIBUTION CHANNEL

- For processing and numeric calibration of one or two signal paths with boron coated ionization chambers
- For monitoring the in-core flux distribution in PWRs with three or six signal paths for in-core SPN-detectors

DSK 250 LOCAL POWER RANGE CHANNEL DMK 250 AVERAGE POWER RANGE CHANNEL

- With four signal paths for in-core fission chambers in the BWR
- Together with the DSK 250 for the average flux and flow related flux calculation in the BWR and for core oscillation monitoring

Architecture of TK 250 signal processing channels for neutron flux monitoring

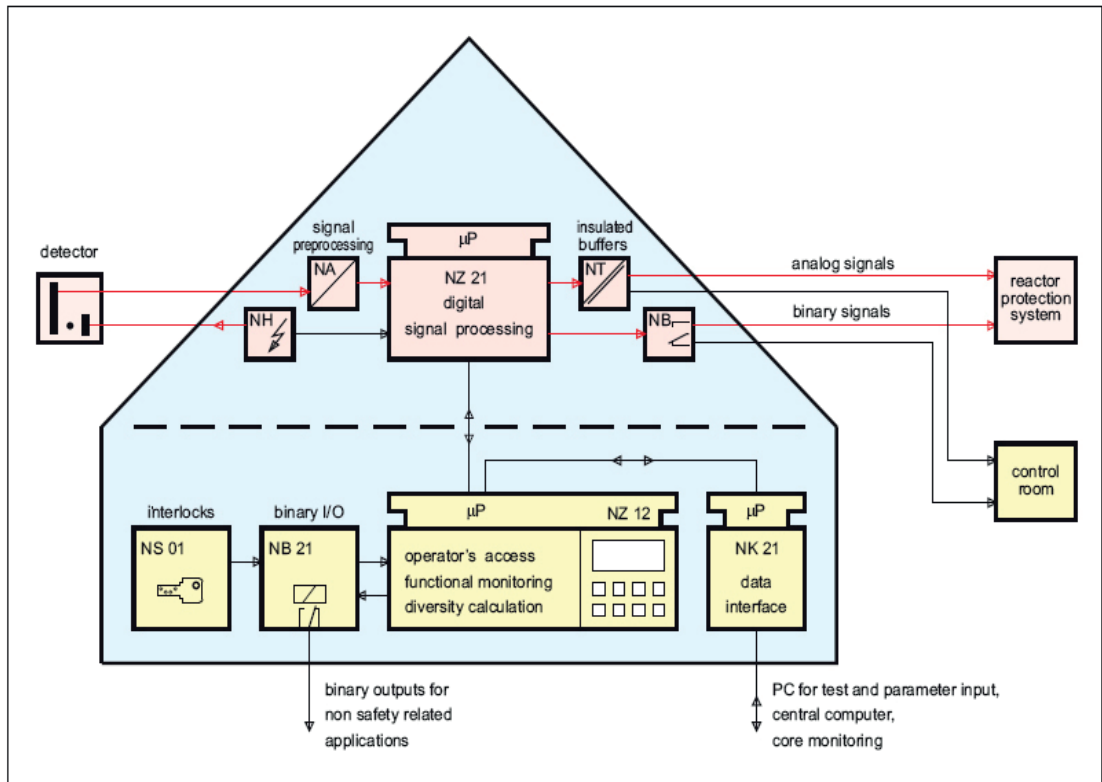

Featuring:



www.mirion.com